

Constructing your deck

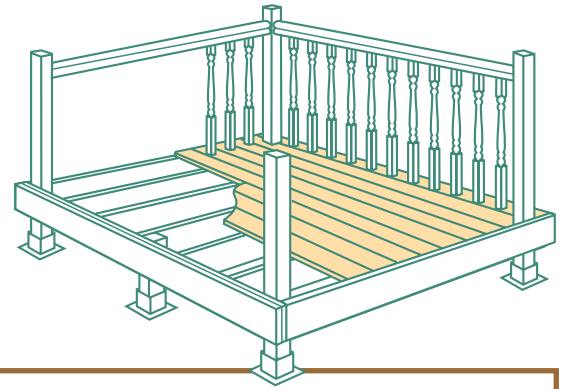

Important information about your decking

1. Always pre-drill pilot holes prior to fixing with screws.
2. Use galvanised steel or deck screws and fixings to eliminate rust stains.
3. Keep posts out of contact with the ground or standing water.
4. To maintain the rich colour of your decking treat it with a pigmented stain or oil. Without treatment, exposure to UV light will cause the colour to fade.

Safety first

- Wear gloves to avoid splinters.
- Avoid prolonged inhalation of sawdust from wood.
- When using power tools wear safety goggles to protect your eyes from the possibility of flying particles.

Tools required

- Spade
- Straight edge or chalk line
- Spirit level
- Galvanised steel or deck screws
- 25mm angle brackets
- Drill and hammer
- Screwdriver
- Handsaw/Powersaw
- Metal post supports
- Post hole borer

How much decking will you need?

To calculate how much decking you'll need to complete your project, simply measure the dimensions of the area you want to deck and then use the tables below to work out how many linear metres you will need.

Using TP 143/144mm softwood decking

Metres	1	2	3	4	5	6	7	8	9	10
1	7	14	21	28	35	42	49	56	63	70
2	14	28	42	56	70	84	98	112	126	140
3	21	42	63	84	105	126	147	168	189	210
4	28	56	84	112	140	168	196	224	252	280
5	35	70	105	140	175	210	245	280	315	350
6	42	84	126	168	210	252	294	336	378	420
7	49	98	147	196	245	294	343	392	441	490
8	56	112	168	224	280	336	392	448	504	560
9	63	126	189	252	315	378	441	504	567	630
10	70	140	210	280	350	420	490	560	630	700

Using 90mm hardwood decking

Metres	1	2	3	4	5	6	7	8	9	10
1	11	22	33	44	55	66	77	88	99	110
2	22	44	66	88	110	132	154	176	198	220
3	33	66	99	132	165	198	231	264	297	330
4	44	88	132	176	220	264	308	352	396	440
5	55	110	165	220	275	330	385	440	495	550
6	66	132	198	264	330	396	462	528	594	660
7	77	154	231	308	385	462	539	616	693	770
8	88	176	264	352	440	528	616	704	792	880
9	99	198	297	396	495	594	693	792	891	990
10	110	220	330	440	550	660	770	880	990	1100

Using 120mm hardwood decking

Metres	1	2	3	4	5	6	7	8	9	10
1	9	18	27	36	45	54	63	72	81	90
2	18	36	54	72	90	108	126	144	162	180
3	27	54	81	108	135	162	189	216	243	270
4	36	72	108	144	180	216	252	288	324	360
5	45	90	135	180	225	270	315	360	405	450
6	54	108	162	216	270	324	378	432	486	540
7	63	126	189	252	315	378	441	504	567	630
8	72	144	216	288	360	432	504	576	648	720
9	81	162	243	324	405	486	567	648	729	810
10	90	180	270	360	450	540	630	720	810	900

Using Thermowood 115mm decking

Metres	1	2	3	4	5	6	7	8	9	10
1	9	18	27	36	45	54	63	72	81	90
2	18	36	54	72	90	108	126	144	162	180
3	27	54	81	108	135	162	189	216	243	270
4	36	72	108	144	180	216	252	288	324	360
5	45	90	135	180	225	270	315	360	405	450
6	54	108	162	216	270	324	378	432	486	540
7	63	126	189	252	315	378	441	504	567	630
8	72	144	216	288	360	432	504	576	648	720
9	81	162	243	324	405	486	567	648	729	810
10	90	180	270	360	450	540	630	720	810	900

Please allow for 5% wastage on all decking calculations

1 Preparing the site

Mark out desired area for deck with timber pegs (47mm x 50mm) and string. This will help you visualise the size of the finished deck and provide a guide for preparing the site. All ground areas need to be firm and suitable for structural support. All earthed areas should be covered with weed control membrane to stop weeds and other growth. If your ground is flat and level you can proceed to Step 3. However if you wish to raise the deck from ground level or the ground is uneven or sloped you should proceed to Step 2.

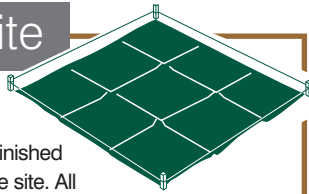

2 Raised deck

A raised deck will need to be supported with fixed posts. The posts should be cut to length and fitted into metal supports at maximum 1800mm centres. If the span between posts is in excess of 1.2m an additional beam support will be required. The bottom of the post should be positioned above ground level so as to allow airflow around the base and drainage of water away from the metal support. Using a level find the desired floor height on the posts. This will give you the position of the top of your beam on the post. Secure the beams to the post as illustrated using stainless steel fixings.

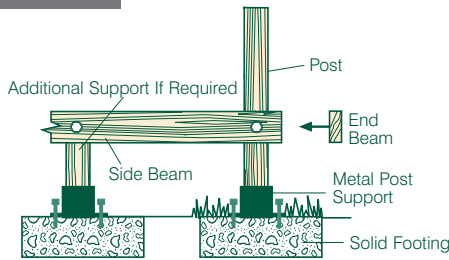

3 Framework

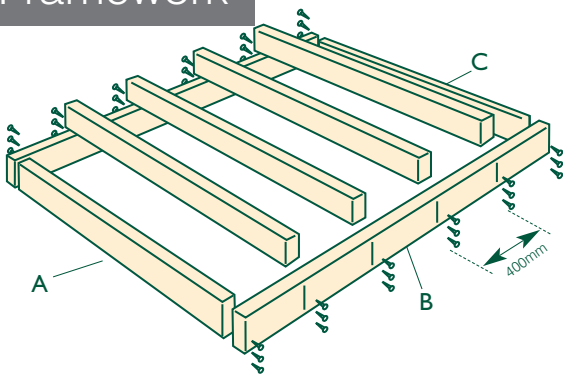

Cut the side joists (A) that will form the sides of the deck to the size you require and mark the position of the floor joists (B) at 400mm centres. Cut the deck floor joists (C) to length and place the floor joists in position where the deck is required. Assemble the framework using 125mm screws. Use three screws or alternatively joist hangers per joist end.

Please note that infill noggins at 1200mm centres should be added for rigidity.

4 Fixing deck boards

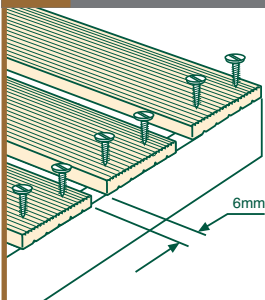

Cut your deck boards to the required length. Place the first board with the end flush with the face of the front of the deck. Fix this first board to each joist with 2 x 75mm stainless steel screws. Always pre-drill a pilot hole prior to fixing. The gap between your boards should be 6mm (use 6mm plywood as template) for drainage. Place the next board parallel to the first and continue in the same way until the last board is laid.

Direction of joists should be at right angles to the decking board.

American system

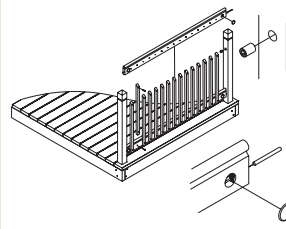

American Balusters, Patrice Newel Post, American Handrail & Balustrade Bolt.

Colonial system

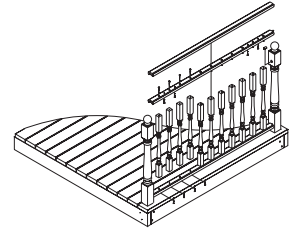

Colonial Spindles, Colonial Newel Post, Traditional Handrail & Balustrade Bolt.

European system

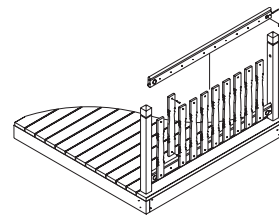

European Balusters, Patrice Newel Post, American Handrail & Balustrade Bolt.

Round handrail system

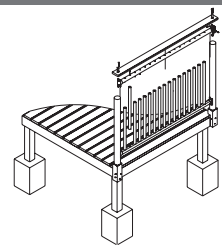

Round Handrail, Round Spindle, Capping Rail, Round Newel & Round Handrail Bracket.

Wavy rail system

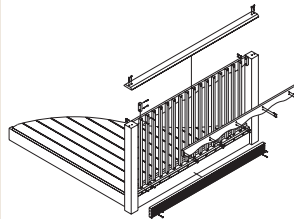

American Baluster, Square Newel, Capping Rail, Wavy Rail and L-rail.

Wavy spindles system

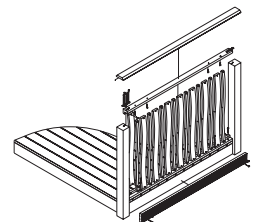

Small or Large Wavy Spindles or a combination of both, Square Newel, L-rail and Capping Rail.

Timber panels, metal panels & balusters

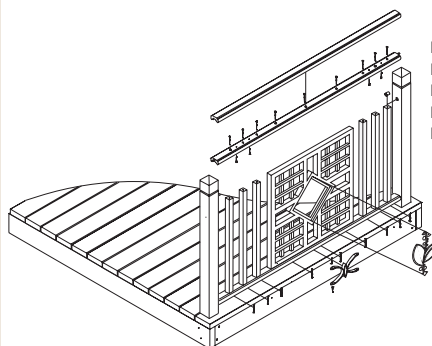

Patrice Newel, Square Baluster, Traditional Rail, Diamond Panel, Leaf & Bernes Infill, Base Rail Support Bracket

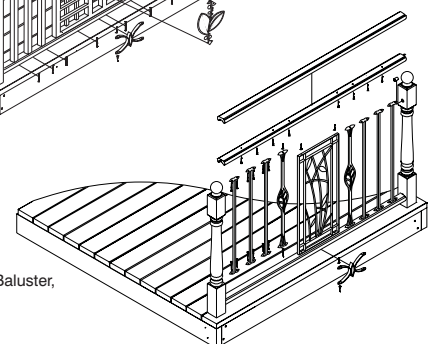

Colonial Newel, Straight Metal Baluster, Contemporary Leaf Metal Baluster, Traditional Rail, Willow Metal Panel, Base Rail Support Bracket